

M900K-90

WC accessories set DN90, 200 mm

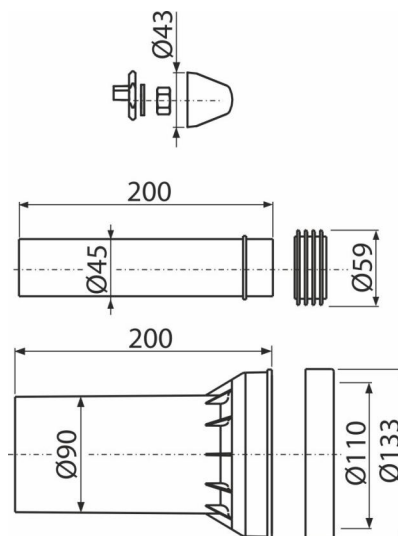

Application

For connecting water and waste to the WC – set
For pre-wall installation systems

Features

- Material: polypropylene, galvanized

Scope of supply

- Direct socket for connecting a wall-hung WC bowl to the waste pipe, polypropylene, Ø90 mm, including seals
- Jumper for connection of wall-hung WC pan to the water supply from the cistern, polypropylene, Ø45 mm, including seals and wrapping seal

Order number, Logistic information

Code	EAN	Weight (piece packing palett)	Dimensions (piece packing)	Quantity (packing palett)
M900K-90	8595580586133	0,49 7,40 138,3 kg	200x200x150 586x386x428 mm	15 240 pcs

Warranty
2/2 years *

Norms
EN 476